

### FEATURES

- PA capable of delivering 22.5 dBm typical power at the antenna port
- SMT configuration

### DESCRIPTION

The MODEL VFM1033A is a 2.5 GHz WiMax picocell front end module (FEM). It is designed to replace all of the RF components that would be typically used in a lower power BTS front end. It is RoHS compliant and lead-free.

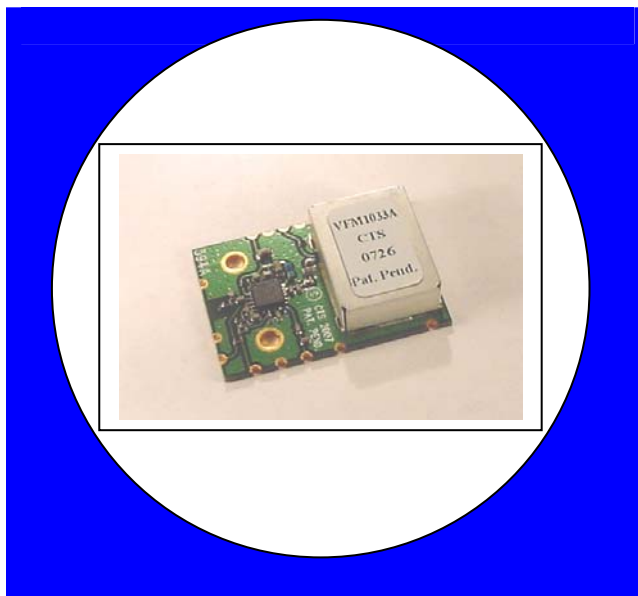

### Block Diagram

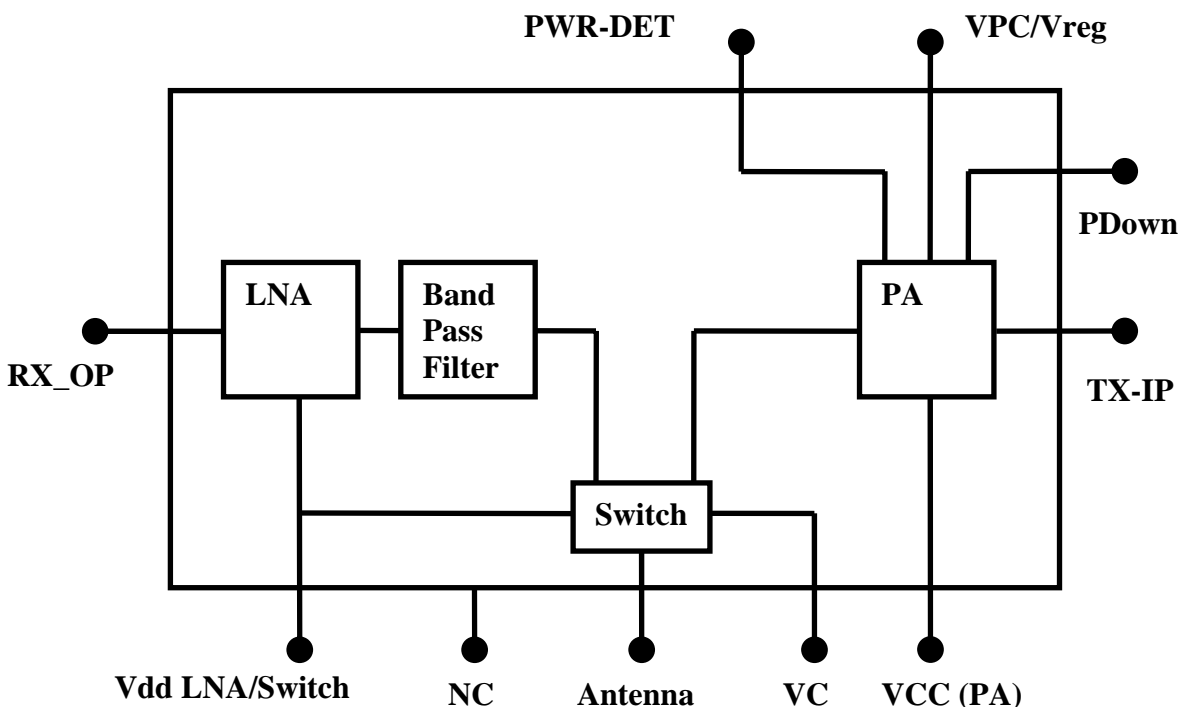

## ELECTRICAL SPECIFICATIONS

### Absolute Maximum Ratings

	min	max	Unit
<b>VC</b>	-0.2	4	V
<b>Vdd</b>	-0.2	4	V
<b>Vcc (PA)</b>	-0.5	5.5	V
<b>VPC/Vreg</b>	-0.5	5	V
<b>PDown</b>	-0.5	5	
<b>VCC(PA) current</b>		800	mA
<b>PWR-DET</b>	-0.5	5	
<b>Tx-IP input power</b>		-5	dBm
<b>ANT VSWR</b>		10:1	
<b>ANT input power</b>		-5	dBm
<b>Operating temperature</b>	-20	75	°C
<b>Storage Temperature</b>	-40	85	°C

### Technical Data

	min	typ	max	Unit	Conditions
<b>Tx frequency band</b>	2496		2690	MHz	
<b>Rx frequency band</b>	2496		2690	MHz	
<b>Power @ ANT port</b>	22	22.5		dBm	PAR = 8 dB
<b>VCC (PA)</b>	4.9	5	5.3	V	
<b>VCC (PA) Current</b>		290	430	mA	60% duty cycle Tx Mode
<b>VPC/Vreg</b>		3.3		V	Tx Mode
<b>Vdd</b>	2.9	3	3.1	V	TX/Rx Mode
<b>LNA/Switch</b>					
<b>Vdd</b>					TX/Rx Mode
<b>LNA/Switch Current</b>		30		mA	

### Switching Data

	min	typ	max	Unit	Conditions
<b>Isolation (See note)</b>		20		dB	V =3V
<b>VC/PDown</b>	2.8	3	3.5	V	Tx Mode
<b>VC/PDown</b>	-0.2	0	0.2	V	Rx Mode

## RF Performance Transmit section

Parameter	Specification			Unit
	min	typ	max	
Frequency	2496		2690	MHz
Gain Tx-IP to ANT	30	33	36	dB
Power at ANT	22	22.5		dBm
EVM @ 22 dBm			2.5	%
ACLR @ 22 dBm	34	38		dB
Antenna return loss		10		dB

Power Detect Voltage vs. Power Out

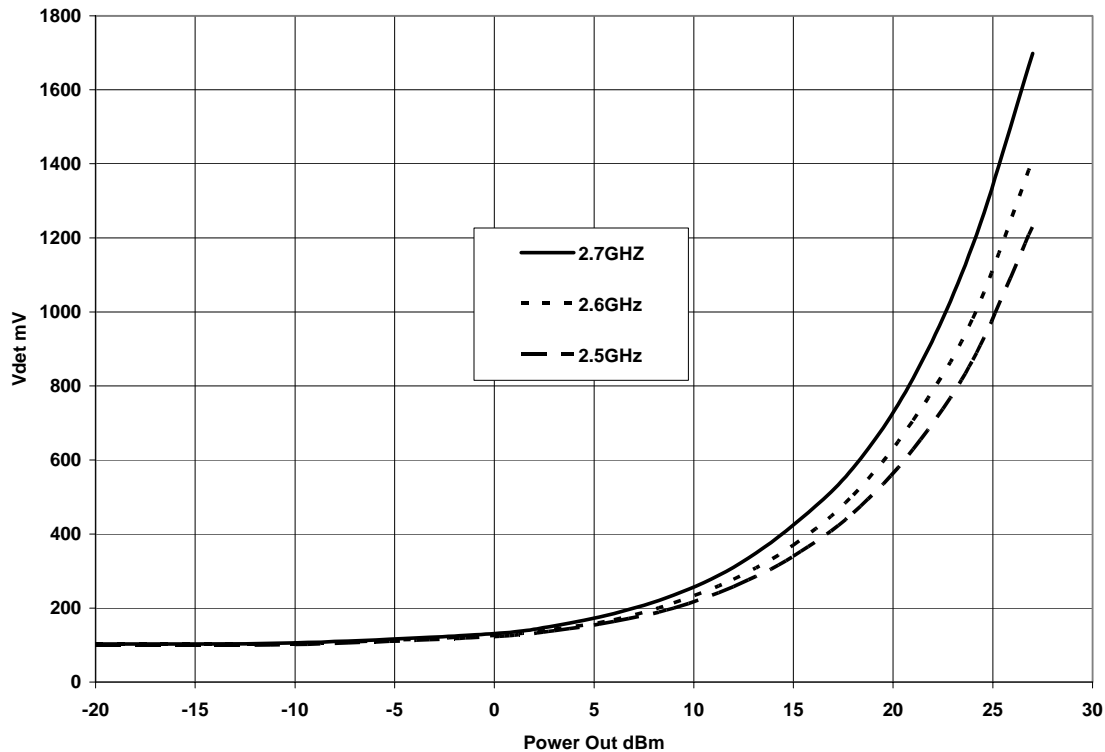

## RF Performance Receive section

Parameter	Specification			Unit
	min	typ	max	
Frequency	2496		2690	MHz
Gain	12.5	15	17.5	dB
Noise Figure		3.3		dB
Rx port return loss		10		dB
Antenna port return loss		10		dB
Out-of-band response..				
Frequency	Attenuation		Reference to Rx output power level	
	min	typ	max	Unit
.1 - 2330	28	40		dB
2856 - 3500	28	39		dB

### NOTES

#### ARCHITECTURE

The VFM1033A is a complete WiMax front end module. The module contains a PA capable of delivering 22 dBm min. at the antenna port while being compliant with 802.16-2005 standards. The receive path maintains an excellent noise figure while providing the required amplification and filtering.

#### **Antenna Switch**

The switch is a GaAs MMIC SPDT switch. It has low insertion loss, good isolation and fast switching speed.

#### *Transmit*

#### **PA**

The PA is a highly efficient InGaP HBT device. It is capable of meeting WiMax requirements. It delivers a guaranteed 22 dBm at the antenna port. It has a “power down” feature.

#### **Power detect**

The PA has a “power detect” output feature, where the output voltage is proportional to power.

#### *Receive*

#### **LNA**

The LNA, switch and bandpass filter together have a noise figure of 3.3 dB and a gain of 15 dB typical. The LNA is very linear.

#### **BPF**

The receive monoblock band pass filter has excellent insertion loss in the passband. This filters other function is to provide the close in blocking needed in order to be compliant with the standard.

## MECHANICAL DRAWING

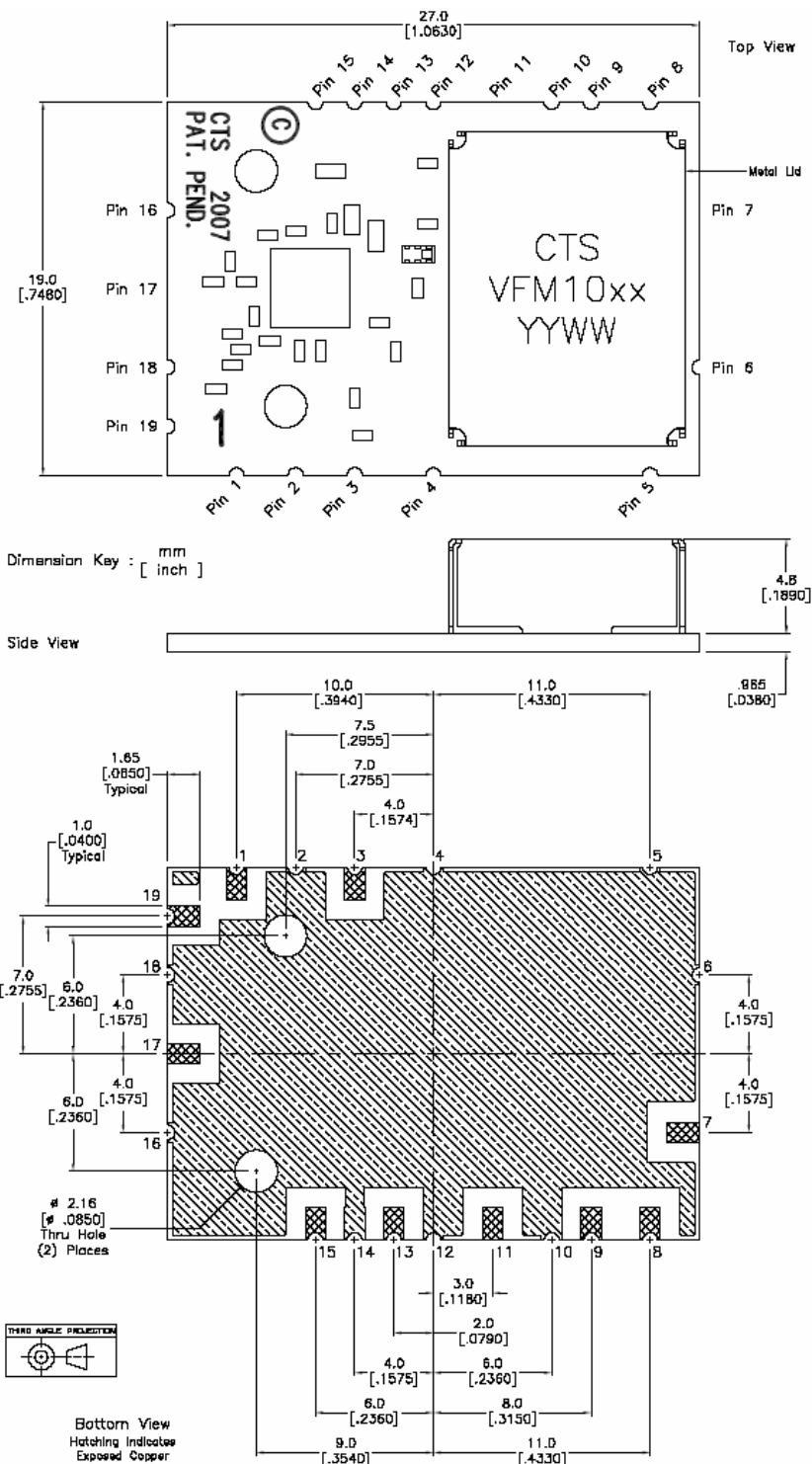

## Customer Recommended PCB Layout

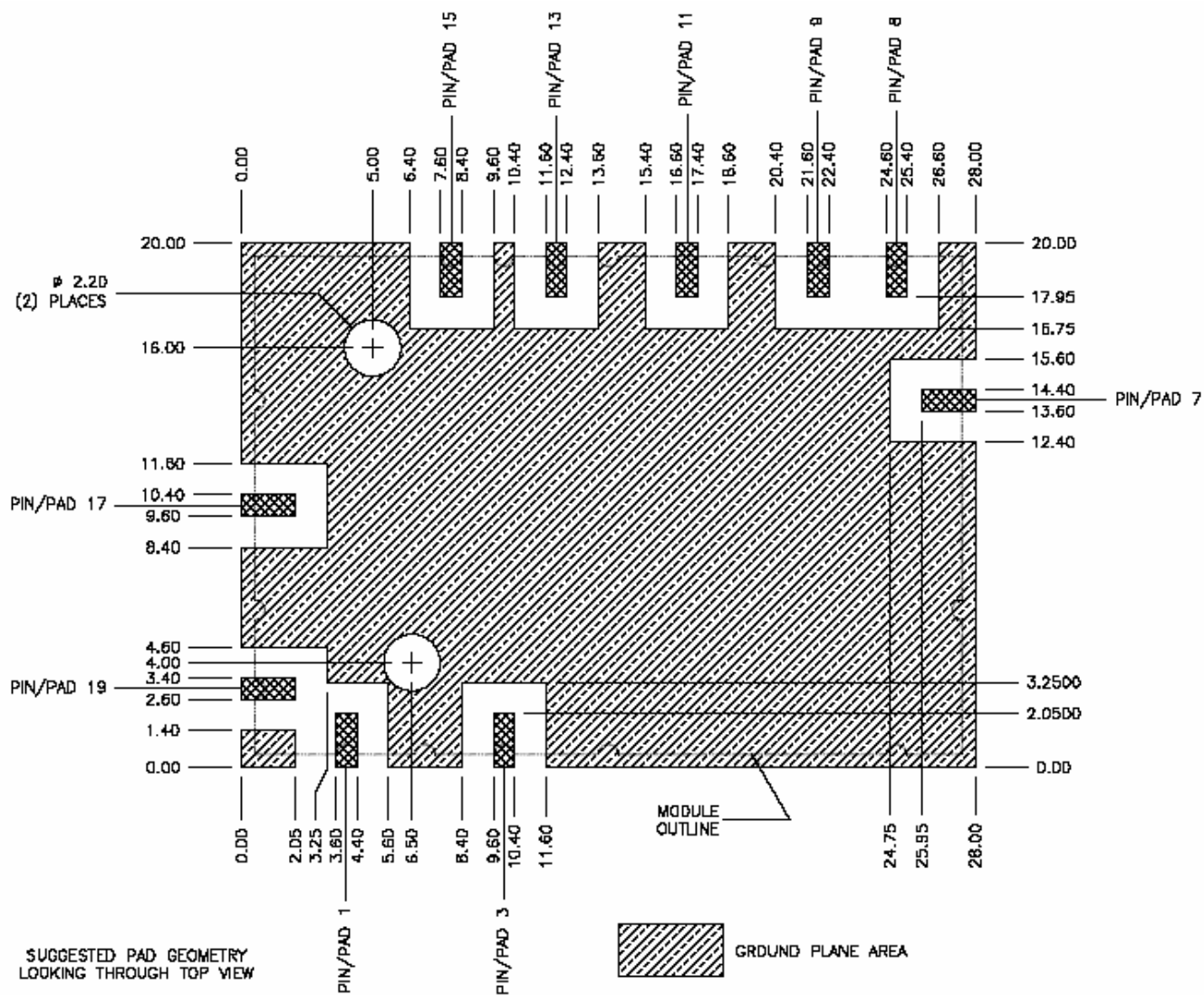

## PIN Description

PIN	SYMBOL	FUNCTION
1	VPC/Vreg	Power Amplifier Bias Voltage
2	GND	Ground
3	PWR_DET	Power Amplifier detector Voltage
4	GND	Ground
5	GND	Ground
6	GND	Ground
7	RX-OP	Receive output
8	Vdd	LNA and Switch supply voltage
9	NC	No internal connection
10	GND	Ground
11	ANTENNA	Antenna connection to switch
12	GND	Ground
13	VC	Switch control: voltage High = Tx Low = Rx
14	GND	Ground
15	VCC (PA)	Power amplifier supply voltage
16	GND	Ground
17	TX-IP	Power Amplifier input
18	GND	Ground
19	Pdown	Pdown: High = Tx Low = Rx

## MODULE CONNECTIONS

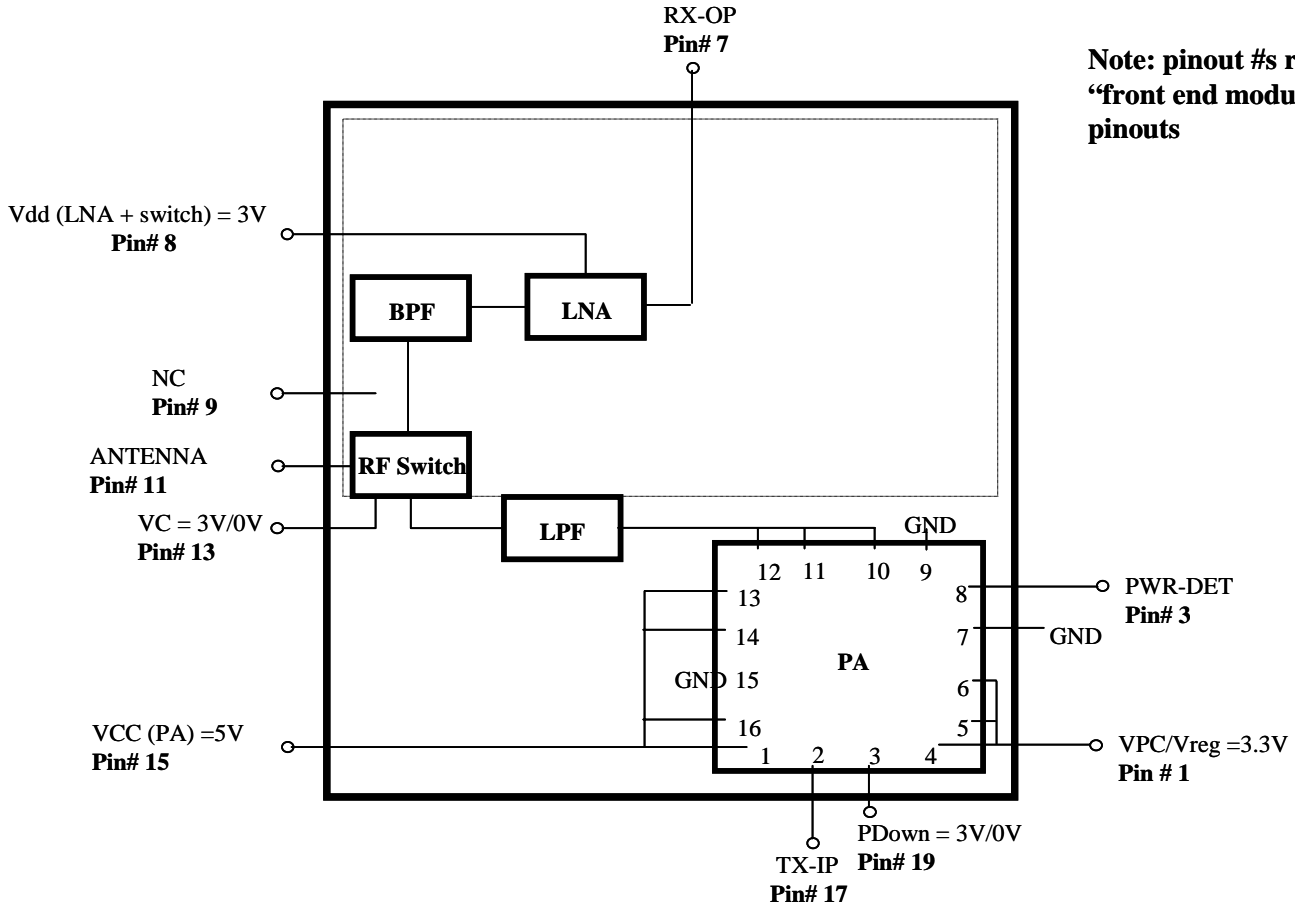

**Note: pinout #s refer to "front end module" pinouts**

### TAPE & REEL INFORMATION

CARRIER TAPE DRAWING:

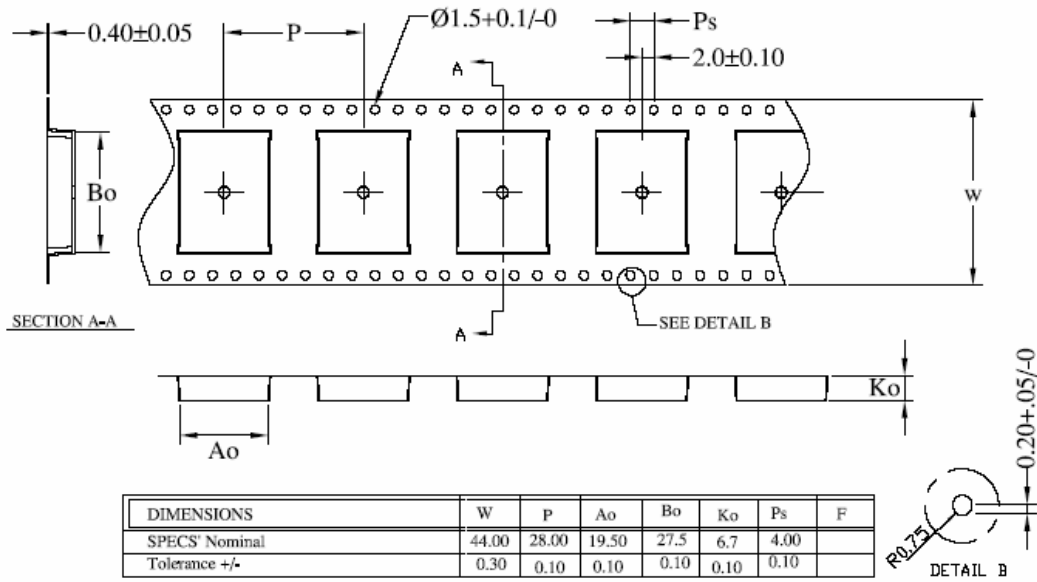

- All dimensions are in mm.
- Carriers do not exceed 1.0 mm in 100mm
- The maximum cumulative tolerance is  $\pm 0.2$  for 10 sprocket hole pitch
- The thickness of carrier tape is 0.4mm