

PRELIMINARY

**EGSM PICOCELL FRONT END MODULE
(Reversed frequencies)**

DESCRIPTION

The MODEL VFM1067A is a EGSM Node B Local Area front end module (FEM). It is designed to replace all of the RF components that would be typically used in a Node B local area front end. It is RoHS compliant and lead-free. It has a patent pending design.

FEATURES

- PA capable of delivering 20 dBm at the antenna port
- Distributed filters offering excellent isolation and harmonic suppression.

Block Diagram

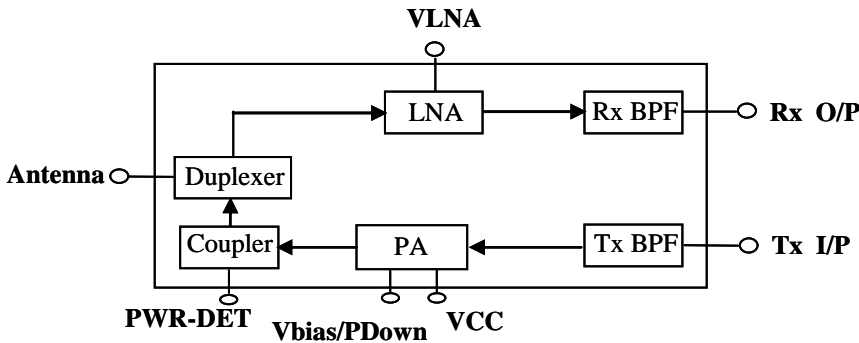

Photo



Typical specifications:

Nominal channel bandwidth: 200 kHz

Specifications:

TRANSMIT	
Frequency range	880 - 915 MHz
PA supply voltage	3.3V
PA bias/Power down	2.8V
PA current drain	100 mA
Power @ antenna port	20 dBm
Tx gain	19 dB
Coupling level for DET	20 dB

RECEIVE	
Frequency range	925 - 960 MHz
LNA supply voltage	3.3V
LNA current drain	90 mA
Noise figure	4.6 dB
Rx gain	19 dB

Tx to Rx response

Rejection @ Rx band (925 - 960 MHz) 44 dB
 Rejection @ Tx band (880 - 915 MHz) 37 dB

Package size: 28.0 x 25 x 6.75 mm

Temp range: -30°C - 75°C