

DESCRIPTION

The MODEL VFM1068A is a GSM850 Rx module. It is ROHS compliant and lead-free.

Block Diagram

Photo

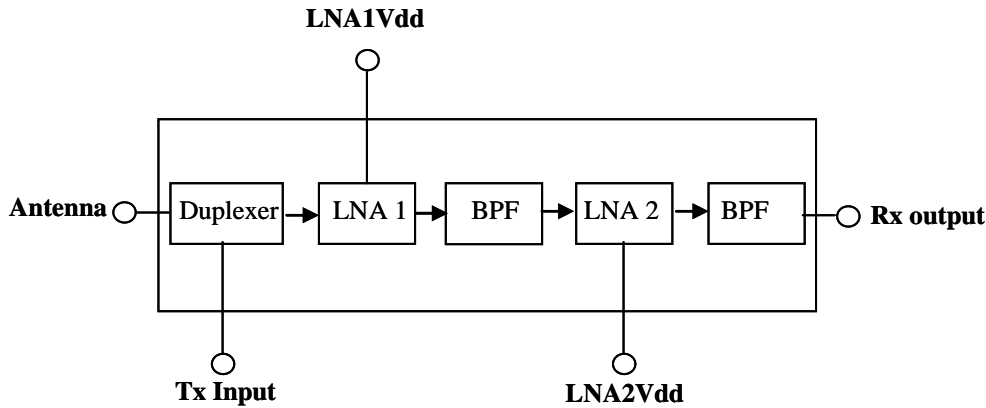

Specifications:

	Typical	Worst case	
Transmit path			
Frequency band	869 - 894 MHz		
Tx power into port		6 watts max.	
Tx Insertion loss	2.6 dB	< -3.4 dB	
Tx port return loss	-12 dB	< -11 dB	
Tx antenna return loss	-12 dB	< -11 dB	
Tx to Rx rejection (duplexer) @ 824 - 849 MHz	-64 dB	< -56 dB	
Tx to Rx rejection (duplexer) @ 869 - 894 MHz	-50 dB	< -43 dB	
Tx power at antenna port		2.5 watts max.	
Receive path			
Frequency range	824 - 849 MHz		
Rx noise figure	3.3 dB	< 4.0 dB	
Rx gain (including duplexer) @ 880 – 915 MHz	23 - 27 dB		
Rx gain (excluding duplexer) @ 925 - 960 MHz	-63 dB	< -50 dB	
Rx gain (including duplexer) @ 738 - 773 MHz	-100 dB	< -75 dB	
Rx P1dB output @ 880 – 915 MHz		> 15 dBm	
Rx IIP3	1 dBm		
LNA #1		LNA #2	
LNA supply voltage	5V	LNA supply voltage	5V
LNA current drain	90 mA	LNA current drain	90 mA
Rx gain	18 dB	Rx gain	18 dB

Temp range: -35 °C - 75°C
 Package size: 53 x 43 x 10.5 mm max.